



# CLC & Capstone

In this assignment, you will essentially be designing your own Game of Life, thinking of situations, and consequently, solutions to factors that could potentially alter your current career-life decisions.

Think about your choices post-graduation; most students are thinking of either some type of post secondary education (college, university, trade school or apprenticeship), working, or travel. Perhaps it is some combination of these three paths, or a different path altogether. Whatever path you choose, factors in your own life, or those in others' lives, may impact your plan, as could trends happening in your community or globally.

In this assignment, you will think of events that could change different post-graduation plans. You can make your own game:

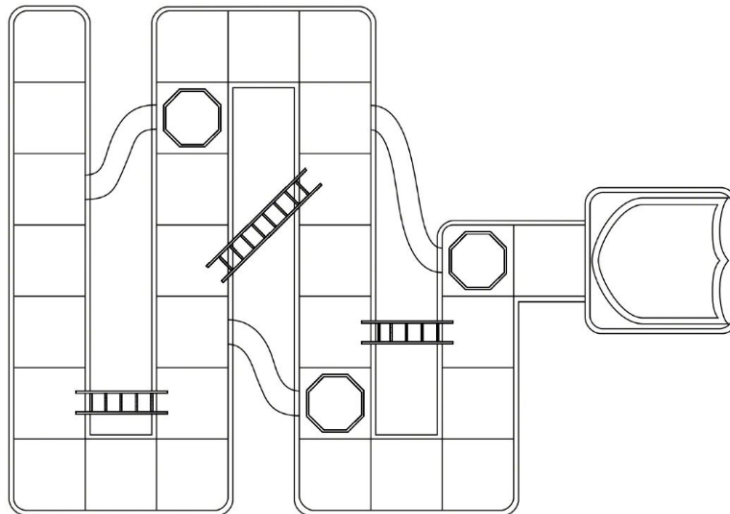

Or you can just go with a table, as in the example below:

Post Graduation Plans		
Post Secondary School...	Working...	Travel...
ex: tuition doubles at your school of choice	ex: trouble finding a job that aligns with your core values	ex: you are no longer able to live where you currently live when you return

1.	1.	1.
2.	2.	2.
3.	3.	3.
4.	4.	4.
5.	5.	5.

### Part One:

Through developing a game, or by using a table, think of at least five major events that would could alter each of the three post-graduation plans. Think beyond small impacts that wouldn't require a lot of flexibility - these should be things that would require a change in the master plan.

### Part Two

Now that you have brainstormed different factors that could influence post-graduation plans, it's time to come up with solutions for them.

Briefly describe your post graduation plans. Using the five situations from part one that could influence the post-graduation plans, describe how you would navigate each situation. What would be your Plan B for each situation?

### Assessment

Game of Life Solutions Rubric



Criteria	Ratings				Pts
Part 1	<p><b>4.0 pts</b> <b>100%</b></p> <p>Student has listed at least five major events that could alter each of the three post-graduation plans. Student has thought beyond small impacts that wouldn't require a lot of flexibility - these are things that would require a change in the master plan.</p>	<p><b>3.0 pts</b> <b>75%</b></p> <p>Student has listed at least three to five major events that could alter each of the three post-graduation plans. Student has thought beyond small impacts that wouldn't require a lot of flexibility - these are things that would require a change in the master plan.</p>	<p><b>2.0 pts</b> <b>50%</b></p> <p>Student has listed less than three major events that could alter each of the three post-graduation plans. Student has not thought beyond small impacts that wouldn't require a lot of flexibility - they are missing the things that would require a change in the master plan.</p>	<p><b>1.0 pts</b> <b>25%</b></p> <p>This portion of the assignment is incomplete.</p>	4.0 pts
Part 2	<p><b>4.0 pts</b> <b>100%</b></p> <p>Student has briefly described their post graduation plans. Using the five situations from part one that could influence the post-graduation plans, student has described how they would navigate each situation and what would be their Plan B for each situation.</p>	<p><b>3.0 pts</b> <b>75%</b></p> <p>Student has briefly described their post graduation plans. Using the three to five situations from part one that could influence the post-graduation plans, student has described how they would navigate each situation. Student may be missing their Plan B for each situation.</p>	<p><b>2.0 pts</b> <b>50%</b></p> <p>Student has briefly described their post graduation plans. Using the three situations from part one that could influence the post-graduation plans, student has, only briefly, described how they would navigate each situation. Student may be missing their Plan B for each situation.</p>	<p><b>1.0 pts</b> <b>25%</b></p> <p>This portion of the assignment is incomplete.</p>	4.0 pts
<b>Total Points: 8.0</b>					